

BATTERY ASSEMBLY TOOLS

Atlas Copco



Introduction – Battery Assembly Tools

True cordless freedom

Atlas Copco's range of industrial battery assembly tools includes both shut-off and transducerized nutrunners and screwdrivers. They allow maximum freedom of movement along the line and inside narrow or closed compartments. Tensor STB tools also offer advanced process control.

The main advantage of battery tools is their superior flexibility due to the absence of cables. This, in turn, improves the efficiency of the operator. Battery assembly tools also contribute to improving safety in the workplace, since there are no air hoses or electric cables to become entangled or jammed. Also, in the automotive industry, for instance, there is no risk of scratches on the car body finish from air hoses or electric cables.

BCP – BCV BATTERY TOOLS - EXPERIENCE CORDLESS FREEDOM

The brushless BCP – BCV tools are ideal for quality critical applications where flexibility is essential. Final assembly of cars, offroad vehicles, buses, trucks, aircraft, motorcycles, engines, and white goods are just some examples of applications which can benefit from the performance and accessibility provided by the BCP - BCV tools. The slim, well-balanced design and ergonomic handle make it a pleasure to hold. Its compact size and Lithium-Ion batteries put it among the lightest battery tools on the market. BCP – BCV tools also offer variable speed and plenty of power, with torque levels ranging from 0.8 up to 45 Nm.

All these ergonomic features make the BCP - BCV the kind of tool you can work with all day long.

TENSOR STB NUTRUNNERS – FAST, LIGHT, TRANSDUCERIZED BATTERY TOOLS

Ergonomically designed Tensor STB pistol-grip (up to 12 Nm) and angle nutrunners (up to 150 Nm) are ideal for safety critical applications in cramped areas. No other battery powered tool can match Tensor STB's unique fastening performance and advanced process control.

Atlas Copco Industrial Radio Communication (IRC) enables the Tensor STB to be partnered with a Power Focus controller for accurate torque monitoring and full joint traceability. At a typical workstation, one Tensor STB tool can be used for several applications within the same torque range.

TENSOR SB NUTRUNNERS – TRANSDUCERIZED BATTERY TOOLS

The Tensor SB allows adjustable torque settings and has a transducer to ensure superior joint quality.

A robust metal housing ensures that the Tensor SB will stand up to tough industrial environments. Also the battery is powerful, reliable and has no memory effect, which means increased uptime for your production.



Powerful, durable and highly operator friendly

For quality critical applications where flexibility is essential, the BCP screwdriver and the BCV nutrunner are the ideal tool choices. Powerful and durable with superior ergonomics and operator feedback they offer higher productivity in assembly operations, independent of the industry.

FREEDOM – TRULY FLEXIBLE ASSEMBLY

- No product damage from cables or hoses
- No trip hazards from trailing cables
- No cable or hose management
- Speed setting functionality
- Reversible battery pack

ERGONOMICS – A PLEASURE TO WORK WITH

- Reduced operator fatigue and work related health problems
- Light, compact and well-balanced design
- Operator feedback

POWER – HIGH PERFORMANCE AND DURABILITY

- Robust and industrial tool design
- Li-Ion battery technology high power-to-weight.



BCP TOOL KEY FEATURES



BCV TOOL KEY FEATURES

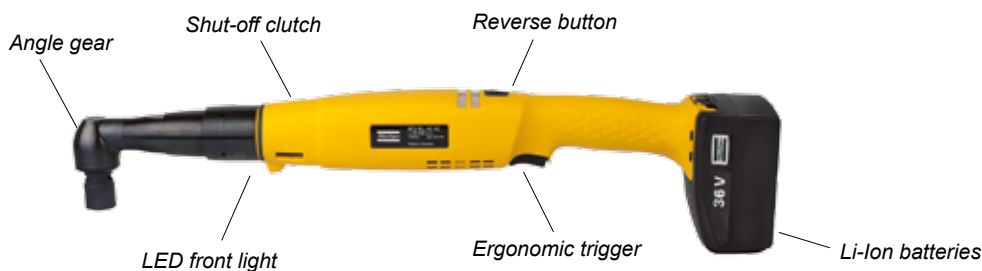

BCP

Screwdrivers – Clutch Type

BCP screwdrivers offer true cordless freedom and superior ergonomics for the operator, thus contributing to outstanding performance.

- Ergonomic, lightweight pistol-grip design.
- 7 brushless models offering variable speed with a speed setting unit.
- Torque range: 0.8-12 Nm.
- Low speed models available.
- Two 18 V batteries: 2.1 Ah flat pack or 4.2 Ah regular pack.



BCP

Model	Square drive in	Torque range		Speed range r/min	Weight (excl. battery)		Length mm	Height mm	Ordering No.
		Nm	ft lb		kg	lb			
BCP BL-2-I06	1/4	0.8-2.5	0.6-1.8	500-1550	0.86	1.89	200	188	8431 1273 00
BCP BL-6-I06	1/4	2.0-6.0	1.5-4.4	300-1000	0.86	1.89	200	188	8431 1273 10
BCP BL-8-I06	1/4	3.0-8.0	2.2-5.9	300-800	0.86	1.89	200	188	8431 1273 20
BCP BL-12-I06	1/4	5.0-12.0	3.7-8.8	250-600	0.86	1.89	200	188	8431 1273 30
BCP BL-2L-I06	1/4	0.8-2.5	0.6-1.8	150-440	0.86	1.89	200	188	8431 1273 50
BCP BL-6L-I06	1/4	1.5-6.0	1.1-4.4	150-440	0.86	1.89	200	188	8431 1273 60
BCP BL-12L-I06	1/4	3.0-12.0	2.2-8.8	150-440	0.86	1.89	200	188	8431 1273 40

-L stands for low speed models.

NOTE: The tools are set at maximum speed at delivery.

All pistol grip models have 1/4" female hexagon drive for bits with quick change chuck.

BCV

Nutrunners – Clutch Type

BCV nutrunners are durable and reliable and offer flexible assembly. A lightweight and handy tool for maximum operator comfort.

- Robust yet ergonomic angle tool.
- Torque range 1.5-45 Nm.
- There are 3 Li-Ion batteries, 18 V (2.1 and 4.2 Ah) and 36 V (2.1 Ah).



BCV

Model	Square drive in	Torque range		Free speed r/min	Weight (excl. battery)		Power W	Battery V	Ordering No.
		Nm	ft lb		kg	lb			
BCV BL-07L-06	1/4	1.5-7	1.1-5.16	120-360	1.15	2.6	340	18	8431 1275 07
BCV BL-07-I06-QC	Hex 1/4	1.5-7	1.1-5.16	400-880	1.15	2.6	830	18	8431 1276 07
BCV BL-15-06	1/4	5-15	3.68-11	200-480	1.15	2.6	970	18	8431 1275 15
BCV BL-15-10	3/8	5-15	3.68-11	200-480	1.15	2.6	970	18	8431 1276 15
BCV BL-30-10	3/8	10-30	7.37-22.12	100-300	1.55	3.4	1720	36	8431 1275 30
BCV BL-45-10	3/8	20-45	14.7-33.2	50-180	1.65	3.6	1490	36	8431 1275 45

Optional Accessories

BATTERIES

Model	Current V	Electric charge Ah	Weight		Charge time min	Ordering No.
			kg	lb		
Li-Ion flat pack	18	2.1	0.37	0.82	35	4211 5526 82
Li-Ion regular pack	18	4.2	0.63	1.39	70	4211 5526 83
Li-Ion (BCV 30/45 Nm only)	36	2.1	0.60	1.32	70	4211 5526 87



Battery
for BCV only

MULTICHARGER FOR BCV, BCP AND STB

Model	Ordering No.
Multicharger 18V - 36V, all regions	4211 5424 85

COVER PROTECTIONS

Model	Ordering No.
Battery cover protection, Flat pack	4211 5601 00
Battery cover protection, Big pack	4211 5602 00
BCV BL-30-10 protective cover	4211 5603 30
BCV BL-45-10 protective cover	4211 5603 45
BCV BL-07/15 protective cover	4211 5603 00
Tool cover protection (BCP only)	4211 5415 00



Battery
Flat pack

MISCELLANEOUS

Model	Ordering No.
Speed setting unit V2 (BCV and BCP)	4211 5462 81
Battery analyzer	4211 5424 90
Support handle	4211 5421 80
Suspension bail	4211 5600 00
Modular tool holder	4220 3584 85



Battery
Big pack

COLOUR RINGS

Model	Ordering No.
Red	4211 5461 02
Orange	4211 5461 03
Green	4211 5461 04
Blue	4211 5461 05
White	4211 5461 06
Purple	4211 5461 07
Grey	4211 5461 08



Colour rings



Battery Multicharger 18V - 36V



Tool holder



Suspension bail



Support handle



Speed setting unit



Battery cover
Flat pack



Battery cover
Big pack



Tool cover

Cordless freedom with full process control

Tensor STB battery powered nutrunners offer the same benefits in terms of process control as Tensor ST nutrunners, yet with the freedom of cordless tools. The tools have the capability to communicate with Bluetooth or W-LAN together with a Power Focus controller, for full process control.

FLEXIBILITY – NO MORE CABLES

- No more cables and cable management
- No more damaged cables
- No product damage from cables
- No trip hazards from trailing cables

PRODUCTIVITY – SAVE TIME

- Increased operator efficiency
- Easy to set up and replace
- Eliminate need for multiple operations
- Faster than competing products

ERGONOMICS

- Reduced operator fatigue and work related health problems
- Unhindered access
- Low weight – up to 20 % lighter than competing products
- Compact size



STB TOOL KEY FEATURES



Tensor STB-X4

Nutrunners – Transducerized Type

- State-of-the-art HMI with extensive functionality.
- Ergonomically designed tool, compact, lightweight, comfortable to work with.
- Durable housing for long service life-time.
- Excellent accessibility in cramped spaces.
- Bigger “foot” enables fast swap of battery.
- Integrated buffer battery maintains WiFi coverage for 30 seconds when battery is changed.
- New built-in external antenna gives superior communication reliability.

STB X4 tools are only compatible with Power Focus 6000 controllers



Model	Square drive in	Torque range		Battery	Speed r/min	Weight		Weight incl. battery		Length mm	Height mm	Ordering No.
		Nm	ft lb			kg	lb	kg	lb			
ETP STB34-06-I06-BD-W	1/4	2-6	2-4	18V	750	1.15	2.5	1.75	3.86	216	240	8433 3019 75
ETP STB34-06-10-BD-W	3/8	2-6	2-4	18V	750	1.15	2.5	1.75	3.86	216	240	8433 3019 25
ETP STB34-12-I06-BD-W	1/4	4-12	3-9	18V	750	1.15	2.5	1.75	3.86	216	240	8433 3019 95
ETP STB34-12-10-BD-W	3/8	4-12	3-9	18V	750	1.15	2.5	1.75	3.86	216	240	8433 3019 97
ETV STB34-15-10-BD-W	3/8	4-15	3-11	18V	720	1.7	3.7	2.35	5.2	435.4	59.7	8433 3019 15
ETV STB34-30-10-BD-W	3/8	6-30	4.5-22	30V	380	1.7	3.7	2.35	5.2	470.8	60.5	8433 3019 35
ETV STB64-50-10-BD-W	3/8	15-50	10-37	30V	365	2.15	4.7	3.1	6.8	507.8	66	8433 3019 65
ETV STB64-70-13-BD-W	1/2	15-70	10-50.7	30V	265	2.65	5.84	3.6	7.9	519.6	76.7	8433 3019 55
ETV STB64-100-13-BD-W	1/2	20-100	15-72.5	30V	170	3.1	6.8	4.05	8.9	556.7	79.1	8433 3019 85

Check with your local Atlas Copco representative regarding availability in your market.

Tensor STB-B

Nutrunners – Transducerized Type

Tensor STB offers genuine ergonomic and flexibility advantages for the operator which, in turn, raises operator efficiency.

- Low tool weight and high spindle speed reduce cycle time.
- Freedom of movement in all working positions.
- Lightweight components help reduce operator fatigue.
- Torque range ETV: 2-150 Nm.
- Torque range ETP: 2-12 Nm.
- Tensor STB-B is also available with ETO and ETC models.



Model	Square drive in	Torque range		Battery	Speed r/min	Weight		Weight incl. battery		Length mm	CS distance	Height mm	Ordering No.	With ball retainer Ordering No.
		Nm	ft lb			kg	lb	kg	lb					
Right-angle standard models														
ETV STB33-10-10-B	3/8	2-10	2-7.5	18 V	943	1.45	3.1	2.05	4.4	435.4	11	41	8433 3020 20	8433 3020 30
ETV STB33-15-10-B	3/8	4-15	3-11	18 V	720	1.5	3.3	2.15	4.75	435.4	11	41	8433 3020 82	8433 3020 96
ETV STB33-20-10-B	3/8	5-20	4-14.5	18 V	480	1.5	3.3	2.15	4.75	469.3	14	41.8	8433 3011 06	8433 3011 16
ETV STB33-30-10-B	3/8	6-30	4.5-22	18 V	380	1.5	3.3	2.15	4.75	470.8	15.5	41.8	8433 3011 67	8433 3021 76
ETV STB63-30-10-B	3/8	6-30	4.5-22	30 V	610	1.8	4	2.75	6.05	495.8	15.5	41.8	8433 3040 21	—
ETV STB63-40-10-B	3/8	12-40	9-29	30 V	450	1.95	4.3	2.9	6.4	507.8	18	47.3	8433 3041 22	8433 3041 39
ETV STB63-50-10-B	3/8	15-50	10-37	30 V	365	1.95	4.3	2.9	6.4	507.8	18	47.3	8433 3042 67	8433 3042 75
ETV STB63-70-13-B	1/2	15-70	10-50.7	30 V	265	2.45	5.4	3.4	7.5	519.6	20	58	8433 3043 05	8433 3043 15
ETV STB63-100-13-B	1/2	20-100	15-72.5	30 V	170	2.9	6.4	3.85	8.5	556.7	22.5	60.4	8433 3044 05	8433 3044 15
ETV STB63-150-13-TM-B	1/2	30-150	22-109	30 V	72	3.4	7.5	4.35	9.6	522.9	23.5	98.1	8433 3045 05	—
Right-angle barcode reader models														
ETV STB33-10-10-BCR-B	3/8	2-10	2-7.5	18 V	943	1.6	3.55	2.2	4.85	435.4	11	41	8433 3020 25	8433 3020 35
ETV STB33-15-10-BCR-B	3/8	4-15	3-11	18 V	720	1.65	3.65	2.3	5.1	435.4	11	41	8433 3020 89	—
ETV STB33-20-10-BCR-B	3/8	5-20	4-14.5	18 V	480	1.65	3.65	2.3	5.1	469.3	14	41.8	8433 3011 11	—
ETV STB33-30-10-BCR-B	3/8	6-30	4.5-22	18 V	380	1.65	3.65	2.3	5.1	470.8	15.5	41.8	8433 3021 69	—
ETV STB63-30-10-BCR-B	3/8	6-30	4.5-22	30 V	610	1.95	4.3	2.9	6.4	495.8	15.5	41.8	8433 3040 28	8433 3040 38
ETV STB63-40-10-BCR-B	3/8	12-40	9-29	30 V	450	2.1	4.6	3.05	6.7	507.8	18	47.3	8433 3041 28	8433 3041 48
ETV STB63-50-10-BCR-B	3/8	15-50	10-37	30 V	365	2.1	4.6	3.05	6.7	507.8	18	47.3	8433 3042 68	8433 3042 78
ETV STB63-70-13-BCR-B	1/2	15-70	10-50.7	30 V	265	2.65	5.85	3.6	7.9	519.6	20	58	8433 3043 10	8433 3043 20
ETV STB63-100-13-BCR-B	1/2	20-100	15-72.5	30 V	170	3.05	6.7	4	8.8	556.7	22.5	60.4	8433 3044 10	8433 3044 20
Pistol-grip standard models														
ETP STB33-06-10-B	3/8	2-6	2-4	18 V	1500	0.95	2.1	1.55	3.4	216	—	208	8433 3120 25	—
ETP STB33-12-10-B	3/8	4-12	3-9	18 V	750	0.95	2.1	1.55	3.4	216	—	208	8433 3121 35	—
Pistol-grip female hex models														
ETP STB33-06-I06-B	1/4	2-6	2-4	18 V	1500	0.95	2.1	1.55	3.4	216	—	208	8433 3120 37	—
ETP STB33-12-I06-B	1/4	4-12	3-9	18 V	750	0.95	2.1	1.55	3.4	216	—	208	8433 3121 48	—
Pistol-grip barcode reader models														
ETP STB33-06-10-BCR-B	3/8	2-6	2-4	18 V	1500	1.1	2.45	1.7	3.75	216	—	235	8433 3120 28	—
ETP STB33-12-10-BCR-B	3/8	4-12	3-9	18 V	750	1.1	2.45	1.7	3.75	216	—	235	8433 3121 38	—
Pistol-grip female hex with barcode reader models														
ETP STB33-12-I06-BCR-B	1/4	4-12	3-9	18 V	750	1.1	2.45	1.7	3.75	216	—	235	8433 3121 58	—
Pistol-grip with P-Set selector														
ETP STB33-06-10-SEB	3/8	2-6	2-4	18 V	1500	1.1	2.45	1.7	3.75	216	—	235	8433 3121 61	—
ETP STB33-12-10-SEB	3/8	4-12	3-9	18 V	750	1.1	2.45	1.7	3.75	216	—	235	8433 3121 63	—
Pistol-grip female hex with P-Set selector														
ETP STB33-06-I06-SEB	1/4	2-6	2-4	18 V	1500	1.1	2.45	1.7	3.75	216	—	235	8433 3121 65	—

Tensor STB-W

Nutrunners – Transducerized Type

Tensor STB offers genuine ergonomic and flexibility advantages for the operator which, in turn, raises operator efficiency.

- Low tool weight and high spindle speed reduce cycle time.
- Freedom of movement in all working positions.
- Lightweight components help reduce operator fatigue.
- Torque range ETV: 2-100 Nm.
- Torque range ETP: 2-12 Nm.
- Supports 2.4 and 5.0 Ghz.



Model	Square drive		Torque range		Battery	Speed r/min	Weight		Weight incl. battery		Length mm	CS distance	Height mm	Ordering No.	With ball retainer Ordering No.
	in	Nm	ft lb	kg			lb	kg	lb						
Right-angle standard models															
ETV STB33-10-10-W	3/8	2-10	2-7.5	18 V	943	1.45	3.1	2.05	4.4	435.4	11	41	8433 3019 00	8433 3019 04	
ETV STB33-15-10-W	3/8	4-15	3-11	18 V	720	1.5	3.3	2.15	4.75	435.4	11	41	8433 3019 08	8433 3019 16	
ETV STB33-20-10-W	3/8	5-20	4-14.5	18 V	480	1.5	3.3	2.15	4.75	469.3	14	41.8	8433 3019 20	8433 3019 24	
ETV STB33-30-10-W	3/8	6-30	4.5-22	18 V	380	1.5	3.3	2.15	4.75	470.8	15.5	41.8	8433 3019 28	8433 3019 32	
ETV STB63-30-10-W	3/8	6-30	4.5-22	30 V	610	1.8	4	2.75	6.05	495.8	15.5	41.8	8433 3019 42	—	
ETV STB63-40-10-W	3/8	12-40	9-29	30 V	450	1.95	4.3	2.9	6.4	507.8	18	47.3	8433 3019 50	8433 3019 54	
ETV STB63-50-10-W	3/8	15-50	10-37	30 V	365	1.95	4.3	2.9	6.4	507.8	18	47.3	8433 3019 58	8433 3019 62	
ETV STB63-70-13-W	1/2	15-70	10-50.7	30 V	265	2.45	5.4	3.4	7.5	519.6	20	58	8433 3019 66	8433 3019 70	
ETV STB63-100-13-W	1/2	20-100	15-72.5	30 V	170	2.9	6.4	3.85	8.5	556.7	22.5	60.4	8433 3019 74	8433 3019 78	
ETV STB63-150-13-W	1/2	30-150	22-109	30 V	72	3.4	7.5	4.4	9.6	522.9	23.5	92.9	8433 3019 81	—	
Right-angle barcode reader models															
ETV STB33-15-B10-BCR-W	3/8	4-15	3-11	18 V	720	1.65	3.65	2.3	5.1	435.4	11	41	—	8433 3019 18	
ETV STB33-20-10-BCR-W	3/8	5-20	4-14.5	18 V	480	1.65	3.65	2.3	5.1	469.3	14	41.8	8433 3019 22	—	
ETV STB33-30-10-BCR-W	3/8	6-30	4.5-22	18 V	380	1.65	3.65	2.3	5.1	470.8	15.5	41.8	8433 3019 30	8433 3019 34	
ETV STB63-30-10-BCR-W	3/8	6-30	4.5-22	30 V	610	1.8	4	2.75	6.05	495.8	15.5	41.8	8433 3019 44	8433 3019 48	
ETV STB63-40-10-BCR-W	3/8	12-40	9-29	30 V	450	2.1	4.6	3.05	6.7	507.8	18	47.3	8433 3019 52	—	
ETV STB63-50-10-BCR-W	3/8	15-50	10-37	30 V	365	2.1	4.6	3.05	6.7	507.8	18	47.3	8433 3019 60	8433 3019 64	
ETV STB63-70-13-BCR-W	1/2	15-70	10-50.7	30 V	265	2.65	5.85	3.6	7.9	519.6	20	58	8433 3019 68	8433 3019 72	
ETV STB63-100-13-BCR-W	1/2	20-100	15-72.5	30 V	170	3.05	6.7	4	8.8	556.7	22.5	60.4	8433 3019 76	8433 3019 80	
Pistol-grip standard models															
ETP STB33-06-10-W	3/8	2-6	2-4	18 V	1500	0.95	2.1	1.55	3.4	216	—	208	8433 3019 82	—	
ETP STB33-12-10-W	3/8	4-12	3-9	18 V	750	0.95	2.1	1.55	3.4	216	—	208	8433 3019 90	—	
Pistol-grip female hex models															
ETP STB33-06-I06-W	1/4	2-6	2-4	18 V	1500	0.95	2.1	1.55	3.4	216	—	208	8433 3019 86	—	
ETP STB33-12-I06-W	1/4	4-12	3-9	18 V	750	0.95	2.1	1.55	3.4	216	—	208	8433 3019 94	—	
Pistol-grip barcode reader models															
ETP STB33-06-10-BCR-W	3/8	2-6	2-4	18 V	1500	1.1	2.45	1.7	3.75	216	—	235	8433 3019 84	—	
ETP STB33-12-10-BCR-W	3/8	4-12	3-9	18 V	750	1.1	2.45	1.7	3.75	216	—	235	8433 3019 92	—	
Pistol-grip female hex with barcode reader models															
ETP STB33-06-I06-BCR-W	1/4	2-6	2-4	18 V	1500	1.1	2.45	1.7	3.75	216	—	235	8433 3019 88	—	
ETP STB33-12-I06-BCR-W	1/4	4-12	3-9	18 V	750	1.1	2.45	1.7	3.75	216	—	235	8433 3019 96	—	
Pistol-grip with P-Set selector															
ETP STB33-06-10-SEW	3/8	2-6	2-4	18 V	1500	1.1	2.45	1.7	3.75	216	—	235	8433 3019 51	—	
ETP STB33-12-10-SEL-W	3/8	4-12	3-9	18 V	750	1.1	2.45	1.7	3.75	216	—	235	8433 3019 91	—	
Pistol-grip female hex with P-Set selector															
ETP STB33-06-I06-SEW	1/4	2-6	2-4	18 V	1500	1.1	2.45	1.7	3.75	216	—	235	8433 3019 53	—	
ETP STB33-12-I06-SEW	1/4	4-12	3-9	18 V	750	1.1	2.45	1.7	3.75	216	—	235	8433 3019 57	—	
Expanded memory models															
ETV STB33-10-B10-WXM	3/8	2-10	2-7.5	18 V	943	1.45	3.2	2.05	4.5	435.4	11	41	8433 3021 11	—	
ETV STB33-30-B10-WXM	3/8	6-30	4.5-22	18 V	380	1.5	3.3	2.15	4.75	470.8	15.5	41.8	8433 3021 33	—	
ETV STB63-30-B10-WXM	3/8	6-30	4.5-22	30 V	610	1.8	4	2.75	6.05	495.8	15.5	41.8	8433 3021 31	—	
ETV STB63-40-B10-WXM	3/8	12-40	9-29	30 V	450	1.95	4.3	2.9	6.4	507.8	18	47.3	8433 3021 41	—	
ETV STB63-50-B10-WXM	3/8	15-50	10-37	30 V	365	1.95	4.3	2.9	6.4	507.8	18	47.3	8433 3021 51	—	
ETV STB63-70-B13-WXM	1/2	15-70	10-50.7	30 V	265	2.45	5.4	3.4	7.5	519.6	20	58	8433 3021 71	—	
ETV STB63-100-B13-WXM	1/2	20-100	15-72.5	30 V	170	2.9	6.4	3.85	8.5	556.7	22.5	60.4	8433 3021 91	—	
ETP STB33-06-10-WXM ^a	3/8	2-6	2-4	18 V	1500	0.95	2.1	1.55	3.4	216	—	208	8433 3021 03	—	
ETP STB33-12-10-WXM ^a	3/8	4-12	3-9	18 V	750	1.1	2.45	1.7	3.75	216	—	235	8433 3021 13	—	

^a With Pset selector premounted.

ETC STB

Tensor STB Crowfoot

IN-LINE CROWFOOT TOOLS

Dimensions

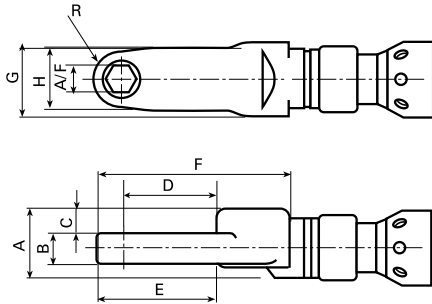

ETC STB

Model	Torque range		Speed r/min	Weight		Length mm	A/F mm	A mm	B mm	C mm	D mm	E mm	F mm	G mm	H mm	R mm	Ordering No.
	Nm	ft lb		kg	lb												
ETC STB63-18-10-LI3	4-18	3-13	470	2.7	5.9	646	10	34	15	12.5	36.7	59.2	82	35	22	10	8433 2316 04
ETC STB63-20-12-LI3	6-23	4-17	226	2.7	5.9	676	12	34	10	15	51.9	54.3	102	35	31	14.5	8433 2316 10
ETC STB63-28-12-LI3	7-28	5-20	226	2.7	5.9	647	12	34	15	12.5	45.5	71	94	35	30	13	8433 2316 07

OFFSET CROWFOOT TOOLS

Dimensions

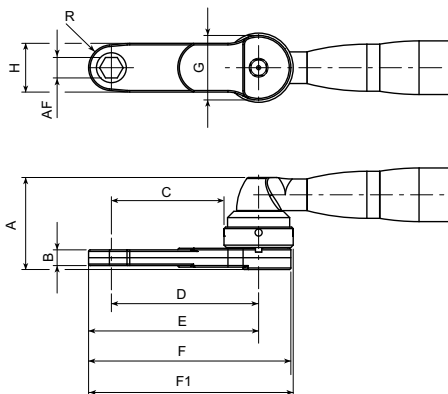

ETC STB

Model	Torque range		Speed r/min	Weight		Length mm	A/F mm	A mm	B mm	C mm	D mm	E mm	F mm	G mm	H mm	R mm	F1 mm	Ordering No.
	Nm	ft lb		kg	lb													
ETC STB63-18-10-LO3	5-18	4-13	610	2.3	5.1	564	10	60.3	15	14.6	32.8	42.8	57.8	36.5	22	10	61.1	8433 2315 02
ETC STB63-20-13-LO5	5-23	4-17	610	2.6	5.7	657	13	58.5	10	71.6	93.6	108.1	128.6	44	31	14.5	130.1	8433 2315 08
ETC STB63-28-12-LO5	6-28	5-20	465	2.9	6.4	656	12	69.5	15	62	84	97	117.5	44	30	13	119	8433 2315 05
ETC STB63-40-14-LO3	8-44	6-32	375	2.8	6.2	620	14	69.5	18	24.8	46.8	61.3	81.8	44	31	14.5	83.3	8433 2315 11
ETC STB63-40-3/8-LO3	8-40	6-29	375	3	6.6	609	3/8	90.3	36	18.2	40.2	50.5	71	44	29	10.3	72.5	8433 2315 17
ETC STB63-50-16-LO3	12-64	8-47	265	3.4	7.5	635	16	78.3	24	27	51	66	88.5	48	30	15	90	8433 2315 20

IN-LINE TUBE NUT TOOLS

Dimensions

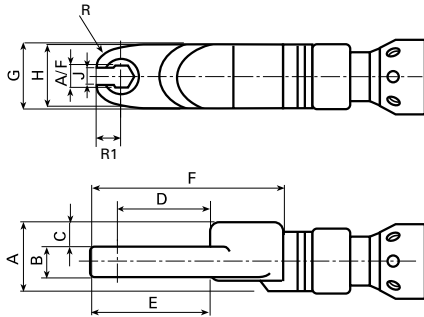

ETO STB

Model	Torque range		Speed r/min	Weight		Length mm	A/F mm	A mm	B mm	C mm	D mm	E mm	F mm	G mm	H mm	J mm	R1 mm	R mm	Ordering No.
	Nm	ft lb		kg	lb														
ETO STB63-8-8-LI3	3-8	2-6	945	2.6	5.7	622	8	32	11	12.3	22.7	21.6	60	33.5	29	6	7.8	10	8433 2316 46
ETO STB63-12-8-LI3	4-12	3-9	723	2.6	5.7	628	8	32	10	13	27.3	25.4	66	33.5	31	7	9.8	11.5	8433 2316 49
ETO STB63-15-10-LI3	4-15	3-11	589	2.6	5.7	629	10	32	12	11	27.9	26.1	68	33.5	32	8	10.3	14	8433 2316 55

OFFSET TUBE NUT TOOLS

Dimensions

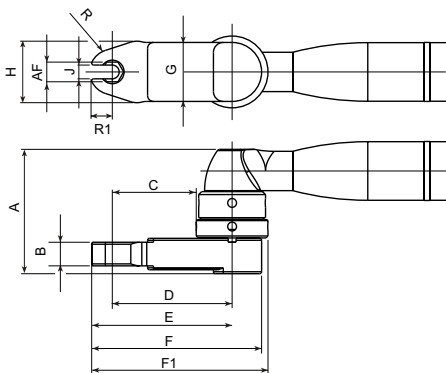

ETO STB

Model	Torque range		Speed r/min	Weight		Length mm	A/F mm	A mm	B mm	C mm	D mm	E mm	F mm	G mm	H mm	J mm	R1 mm	R mm	F1 mm	Ordering No.
	Nm	ft lb		kg	lb															
ETO STB33																				
ETO STB33-12-10-LO5	3-12	2-9	480	2.3	5.1	596	10	62	10	42.7	60.9	70.7	85.7	36.5	31	7	9.8	11.5	89	8433 2315 59
ETO STB33-15-10-LO3	4-14	3-10	480	2.3	5.1	560	10	63.3	12	7	25.1	34.9	49.9	36.5	31	7	9.8	11.5	53.2	8433 2315 56
ETO STB63																				
ETO STB63-18-12-LO5	4-18	3-13	610	2.6	5.7	634	12	62	11	51	73	84.9	105.4	44	38	8	11.9	15	107	8433 2315 68
ETO STB63-20-12-LO3	5-20	3-15	610	2.4	5.3	589	12	64	14	7	29	40.2	60.7	44	38	8	11.2	14	62.2	8433 2315 65
ETO STB63-30-13-LO5	10-33	7-24	265	3.8	8.4	647	13	72.5	18	53.3	75.3	87.7	108.2	44	40	10.4	12.4	25	109.7	8433 2315 74
ETO STB63-28-13-LO3	6-28	4-21	465	2.8	6.2	611	13	65	11	12.8	36.8	51.8	74.3	48	50	10.4	15	31	75.8	8433 2315 77
ETO STB63-40-17-LO5	10-50	7-37	265	3.6	7.9	675	17	80.5	18	66.8	90.8	105.8	128.3	48	50	12	15	31	129.8	8433 2315 80
ETO STB63-50-17-LO3	11-60	8-44	265	3.6	7.9	628	17	77.8	18	11.1	42.4	59.6	85.6	62.5	59	14	17.2	32	90.9	8433 2315 83
ETO STB63-50-21-LO3	11-55	8-40	265	3.6	7.9	638	21	73.8	12	18	49.2	69.3	96.8	62.5	59	16	20.1	32	100.6	8433 2315 86

Optional Accessories

CONTROLLER HARDWARE

Model	Ordering No.
Power Focus 4000 W 10	
PF 4000-G-HW	8433 7100 00
PF 4000-C-HW	8433 7100 05
PF 4000-G-DN- HW	8433 7140 00
PF 4000-C-DN-HW	8433 7140 05
PF 4000-G-PB-HW	8433 7142 00
PF 4000-C-PB-HW	8433 7142 05
PF 4000-G-CC-HW	8433 7143 00
PF 4000-C-CC-HW	8433 7143 05
PF 4000-G-IB-HW	8433 7145 00
PF 4000-C-IB-HW	8433 7145 05
PF 4000-G-PN-HW	8433 7148 00
PF 4000-C-PN-HW	8433 7148 05
PF 4000-G-EIP-HW	8433 7149 00
PF 4000-C-EIP-HW	8433 7149 05
IRC Focus W 10 Bluetooth*	
IRC FOCUS-B-G-HW	8433 6500 00
IRC FOCUS-B-C-HW	8433 6500 02
IRC FOCUS-B-G-DN-HW	8433 6500 04
IRC FOCUS-B-C-DN-HW	8433 6500 06
IRC FOCUS-B-G-PB-HW	8433 6500 12
IRC FOCUS-B-C-PB-HW	8433 6500 14
IRC FOCUS-B-G-PN-HW	8433 6500 24
IRC FOCUS-B-C-PN-HW	8433 6500 26
IRC FOCUS-B-G-EIP-HW	8433 6500 28
IRC FOCUS-B-C-EIP-HW	8433 6500 30

*) IRC Focus Communication kit is not needed. The IRC Focus is specially designed for the Tensor STB. The benefit is that the IRC Radio is integrated inside the IRC Focus. The IRC Focus has all the features of a Power Focus, with the exception that it cannot be used with cabled tools. IRC Focus is only available for Bluetooth tools.

TOOLSTALK PF

No. of users	Ordering No.
Basic version W 10	
1-user license	8092 1190 01
5-user license	8092 1190 05
10-user license	8092 1190 10
Plant license	8092 1190 99
Upgrade from W 7 to W 10	
1-user license	8092 1190 31
5-user license	8092 1190 35
10-user license	8092 1190 40
Plant license	8092 1190 49

COM KIT

	Ordering No.
Com kit (minimum PF SW 7.5)	
Com kit IRC-B (Bluetooth)	8433 3900 20
Com kit IRC-W (W-LAN)	8433 3900 35
NOTE: Kit includes: Serial port adapter, I/O cable, 3 m serial cable and power cable.	

CONTROLLER SOFTWARE

Controller software	Ordering No.
RBU-Bronze	8433 0010 10
RBU-Silver	8433 0015 20
RBU-Gold	8433 0020 20

MULTICHARGER

Model	Ordering No.
Multicharger 18V - 36V, all regions	4211 5424 85

BATTERY – LI-IO

Voltage	Capacity	Weight		Ordering No.
			kg	
18 V	4.2 Ah	0.60		4211 5526 83
30 V	2.6 Ah	0.85		4211 5586 88

ACCESSORIES FOR IRC AND POWER FOCUS 4000 CONTROLLER

	Ordering No.
Operator panel advanced	8433 0565 00
Stacklight ESL04	8433 0570 13
Selector 4	8433 0610 04

TOOL ACCESSORIES

	Ordering No.
ETV STB33 (10/15/20/30 Nm models)	
ETV STB63 (30/40/50 Nm models)	
Barcode scanner	8433 0615 10
Parameter set selector	8433 0616 05
I/O Device module	8433 0617 12
Adjustable headlights	4220 3292 94
Lever trigger 135	4220 3311 90
Lever trigger on top	4220 3186 90
Front button	4220 3184 90
Scanner protective cover	4220 2917 06
ETV STB63 (70/100 Nm models)	
Barcode scanner	8433 0615 20
Parameter set selector	8433 0616 15
I/O Device module	8433 0617 22
Adjustable headlights	4220 3292 95
Lever trigger 135	4220 3311 91
Lever trigger on top	4220 3186 91
Front button	4220 3184 91
ETP STB33 (06/12 Nm models)	
Barcode scanner	4220 3507 90
Parameter set selector	4220 3507 81
Scanner protective cover	4220 2917 06



Stacklight ESL-04



Operator panel advanced



Selector 4



Tool holder



Lever trigger top



Lever trigger 135 deg.



Adjustable headlights



Front trigger button



Barcode scanner



Parameter set selector

Tensor SB-B

Nutrunners – Transducerized Type

Tensor SB is Atlas Copco's response to customers who demand a truly superior industrial battery nutrunner. This user-friendly tool is characterized by a combination of quality in every tightening, operator mobility and long-lasting durability. Together these advantages give Tensor SB a unique position on the market.

- Low tool weight and high spindle speed increases productivity.
- Durable metal housing.
- Freedom of working freely in any position.
- Torque range ETV: 2-140 Nm.
- Torque range ETP: 4-12 Nm.
- Connects through Bluetooth.



Model	Square drive in	Torque range		Battery	Free speed r/min	Weight		Weight incl. battery		Length mm	CS distance	Height mm	Ordering No.
		Nm	ft lb			kg	lb	kg	lb				
Angle													
ETV SB33-10-10-B	3/8	2-10	2-7.5	Li-Io 18 V	975	1.3	2.9	1.9	4.2	455	14	42	8433 3031 20
ETV SB33-15-10-B	3/8	4-15	3-11	Li-Io 18 V	720	1.3	2.9	1.9	4.2	455	14	42	8433 3031 82
ETV SB33-30-10-B	3/8	6-30	4.5-22	Li-Io 18 V	380	1.6	3.55	2.2	4.85	471	15.5	42	8433 3031 66
ETV SB63-40-10-B	3/8	12-40	9-29	Li-Io 30 V	450	1.85	4.1	2.8	6.15	508	18	47.5	8433 3031 23
ETV SB63-50-10-B	3/8	15-50	10-37	Li-Io 30 V	360	1.85	4.1	2.8	6.15	508	18	47.5	8433 3031 67
ETV SB63-70-13-B	1/2	15-70	10-50.7	Li-Io 30 V	265	2.9	6.4	3.85	8.45	533	20	58	8433 3031 05
ETV SB63-100-13-B	1/2	20-100	15-72.5	Li-Io 30 V	170	3	6.6	3.95	8.7	557	22.5	60.5	8433 3031 10
ETV SB63-140-13-B	1/2	20-140	15-101.5	Li-Io 30 V	120	3.4	7.5	4.4	9.7	593	25	65	8433 3031 15
Pistol													
ETP SB33-12-106-B	1/4	4-12	3-9	Li-Io 18 V	750	0.95	2.1	1.6	3.55	216	—	208	8433 3031 49

Optional Accessories

CONTROLLER HARDWARE

Model	Ordering No.
Power Focus 4000 W 10	
PF 4000-G-HW	8433 7100 00
PF 4000-C-HW	8433 7100 05
IRC Focus W 07 Bluetooth*	
IRC FOCUS-B-G-HW	8433 6500 00
IRC FOCUS-B-C-HW	8433 6500 02

*) IRC Focus Communication kit is not needed.

CONTROLLER SOFTWARE

Controller software	Ordering No.
RBU SB	8433 0081 00

TOOLSTALK POWER FOCUS

No. of users	Ordering No.
Basic version W 10	
1-user license	8092 1190 01

COM KIT

	Ordering No.
Com kit (minimum PF SW 7.5)	
Com kit IRC-B (Bluetooth)	8433 3900 20

NOTE: Kit includes: Serial port adapter, I/O cable, 3 m serial cable and power cable.

BATTERY – LI-IO

Voltage	Capacity	Weight kg	Ordering No.
18 V	4.2 Ah	0.60	4211 5526 83
30 V	2.6 Ah	0.85	4211 5586 88

MULTICHARGER

Model	Ordering No.
Multicharger 18V - 36V, all regions	4211 5424 85



Battery Big pack



Battery multicharger 18V - 36V